



**QUALITY  
MADE IN AUSTRIA**

- **EN 1090**
- **ETA-17/0461**
- **Passivhouse certified**

# **SPIDI**®

**Professional fixing system for  
ventilated facades & suspended ceilings**



## THE INNOVATIVE SYSTEM

The substructure behind a ventilated facade is the deciding factor for the wide range of its design options as well as its safety. Architects, developers and installation companies trust the patented SPIDI® facade system for this task.

It allows them to achieve the perfect finish for their facades, offering highest-grade workmanship, structural stability and optimal thermal insulation in an economical way.

With over 45 years of experience and collaborations with renowned European facade cladding manufacturers, the SPIDI® system represents a competent solution for the quick and safe installation of facades made of any material by providing established system solutions as well as special customized designs.

**Marina Tower**  
Vienna  
Eternit, 20.000 m<sup>2</sup>

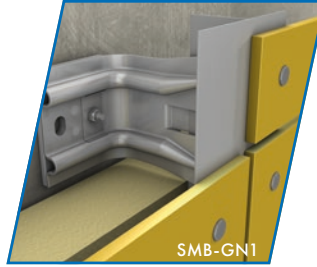

## The SPIDI® Facade System

The certified SPIDI® façade system is suitable for fixing all types of ventilated façades, for all types of cladding and building heights. The patented SPIDI® max wall brackets are ETA-approved and are manufactured from high-strength aluminum, steel with extended corrosion protection through cathodic dip coating and stainless steel A2 or A4. The stainless steel brackets are also Passive House certified.

SPIDI® max wall brackets have a pre-mounted thermostop, can be installed as fixed or sliding points, both horizontally and vertically. This speeds up installation work, reduces the risk of errors and saves on storage costs.

### Key features:

- ISO 9001 and ISO 14001 certified and tested in compliance with current standards and regulations.
- Certified according to EN 1090-1, evaluated acc. to EAD 090034-00-0404
- The SPIDI® max stainless steel brackets are passive house certified.
- Secure attachment to the primary building using certified fixing elements, the pre-mounted Thermostop and SPIDI® max washer plates.
- Available in aluminium, steel or stainless steel for highest heat transition coefficient requirements.
- Maximum torsional stiffness is provided by end-to-end stiffening ribs.
- Seamless compensation of building tolerances up to ~40mm with spring clips.
- Wall-to-panel distances between 40 and ~900mm are possible.
- High insulation thicknesses for low energy housing can be accommodated without problems.
- Our special profiles are carefully selected to suit the project's cladding materials, and can be coated or treated as required.

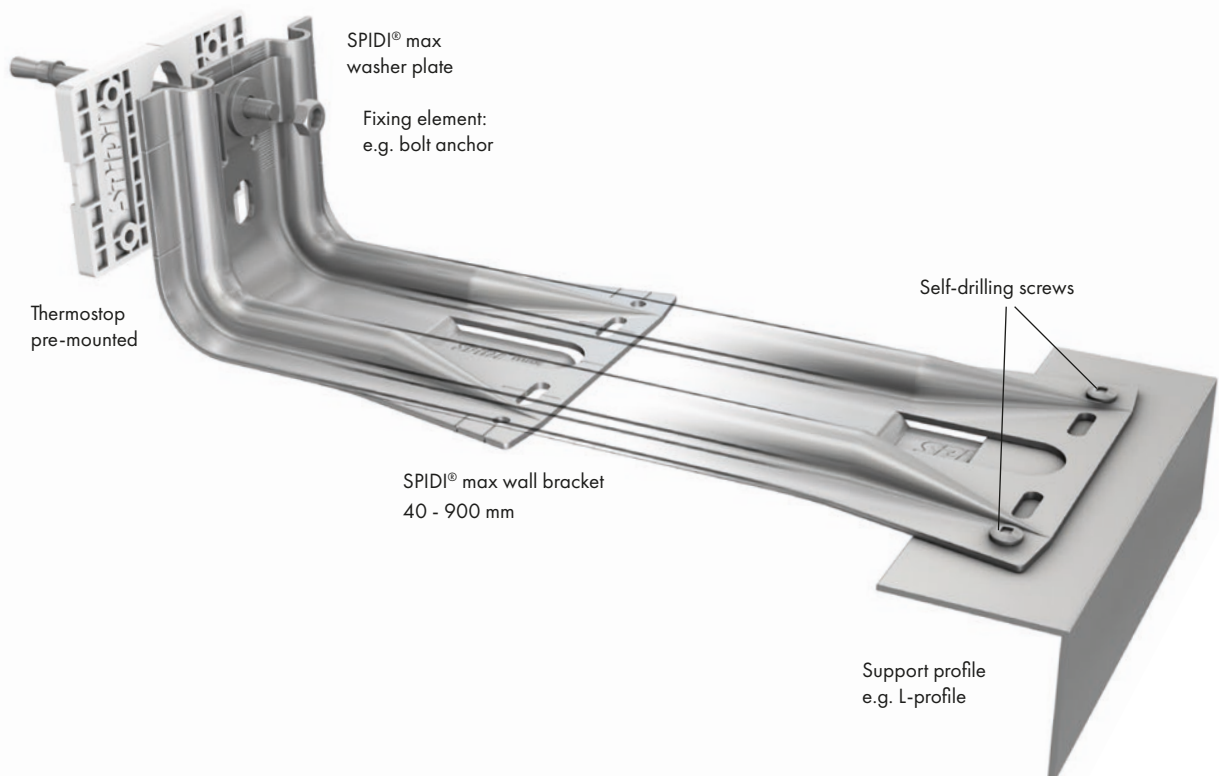



## **FLEXIBILITY WITHIN THE SYSTEM**

The ventilated facade has established itself as the optimal system for facade engineering and construction. The SPIDI® facade system is prepared for even the most ambitious architectural designs. Construction projects of any size can be built to perfection using the SPIDI® facade system - including everything from small areas for a family house to large scale projects and beyond.

The SPIDI® facade system is a highly flexible fixing system, allowing for any thickness of thermal insulation and compensating for large structural tolerances with ease. As a non-combustible facade system it meets all building regulations requirements. All types of masonry (brick, concrete, etc.), steel structures, and solid timber are suitable substrates for the SPIDI® facade system.

**University and  
Research Center Tulln/**  
Austria  
Timber/Fiber cement, 4500 m<sup>2</sup>

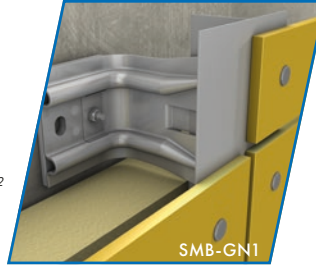

## The Perfect Solution for any Construction Project

The same project often requires a variety of solutions, be it due to varying wind loads on different sides of the building, due to the fixing components' varying load properties, or the range of cladding materials used.

In order to achieve the best results, we will meet you on-site to discuss local conditions, assess permissible loads for fixing components on the given substrate, and take site measurements. Based on this we determine the fixing system best suited for the facade cladding in question.



## Custom Solutions

In addition to our numerous time-honoured system solutions, we often encounter situations that require a new approach. In these cases, the SPIDI® technical team will be ready to advise you and with our wide range of SPIDI® system options we will find the best suitable answer to your planning and implementation questions.

A **sloping facade** can be realized easily and economically using different lengths of SPIDI® wall brackets. For cladding **curved structures**, the SPIDI® facade system's support profiles can be curved and fitted with additional holes to ensure unhindered ventilation. To achieve any desired colour in the joint areas, support profiles can be coated or anodized before delivery, or undergo other treatments as requested. The same options are available for made-to-measure sheet metal flashing.

The SPIDI® facade system can be installed vertically or horizontally as required. Correct ventilation of the structure is ensured by setting the appropriate wall-to-panel distance and fitting support profiles with additional holes where required. Combining different lengths of SPIDI® wall brackets is an easy way to compensate for large wall-to-panel distances where protrusions or recesses are present in the facade (such as in renovation projects, for installations of sun blinds, shutters, etc.).

The SPIDI® substructure system is even suitable for ceiling suspension projects, providing a solution for mounting distances of more than one meter easily and economically.

# BUILDING PHYSICS PERFORMANCE

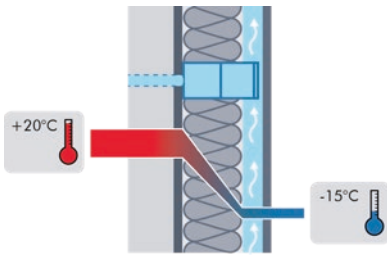

## Thermal Insulation and Temperature Control

A rear ventilated facade structure that is correctly insulated will keep the interior environment balanced throughout the year. During summer, sunlight is reflected or absorbed, preventing solar heat gain on the facade. During winter, the insulation layer serves as heat storage. Tailored insulation solutions, such as those used in "passive-home-technology", provide the best possible protection and temperature control.

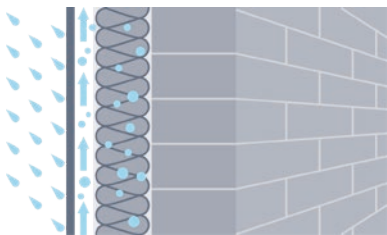

## Protection against Moisture and Condensation

Moisture travelling from inside the building to the outside requires the insulation thickness to be calculated correctly, so that the dew point lies in the outer third of the insulation layer. This allows moisture to be carried effectively outside via the constant airflow in the ventilation space behind the facade cladding, which also prevents the masonry from growing damp over time.

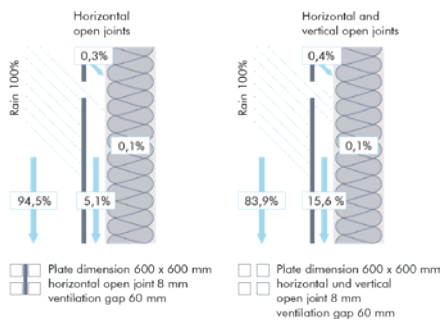

## Protection against Rain

The German industry standard DIN 4108-3 classifies rear ventilated facades as highly exposed to driving rain (category III). They are rainproof against driving rain by their structural design. The ventilation cavity between insulation and facade cladding acts as a pressure equalization zone. Moisture that may have entered through cladding joints can drain off the back of the cladding, preventing water from seeping into the insulation material.



## Protection against Fire

All fire safety requirements can be met in compliance with building regulations by choosing proper components for your rear ventilated facade structure. This consists of the thermal insulation, the non-combustible SPIDI® facade system including all fixing and the cladding.

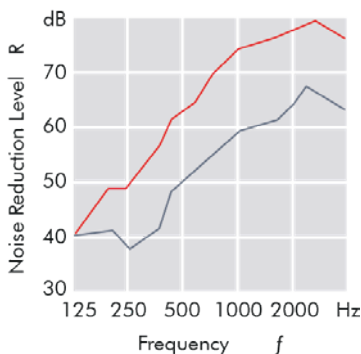

## Protection against Noise

The structural design of rear ventilated facades allows for sound waves to be reflected off the cladding as well as absorbed into the thermal insulation. This significantly reduces noise pollution. The diagram shows a bare solid wall in comparison with an insulated rear ventilated facade, the latter showing significantly improved acoustic protection. Depending on insulation thickness and type of cladding, it is possible to reduce noise pollution by up to 12 dB.

# TECHNOLOGY AND APPLICATION

The SPIDI® facade system complies with all regulations, standards and laws that apply to the implementation of ventilated facades. SPIDI® wall brackets can be installed vertically or horizontally as appropriate for the given facade cladding material as well as building physics and structural engineering requirements. The standards for facade ventilation require an unobstructed ventilation cross-section of a minimum of 200 cm<sup>2</sup>/m. In air intake and exhaust areas, the open ventilation cross-section must be at least 50 cm<sup>2</sup>/m.

Structural calculations to determine the dimensioning of the facade system are based on wind load (positive and negative pressure), the facade's dead load, and tensions in the materials that result from changes in temperature.



SPIDI® wall brackets are installed as either fixed or sliding points to absorb these forces:

- A **fixed point** absorbs a share of the wind load and carries the facade's dead load. The round holes in SPIDI® wall brackets are used to attach them as fixed points to the support profile with rivets or self-drilling stainless steel screws.
- A **sliding point** absorbs wind load and tension caused by material expansion/contraction from changes in temperature. To create a sliding point, SPIDI® wall brackets are attached to the support profile through the slotted holes, using sliding rivets or self-drilling stainless steel screws.

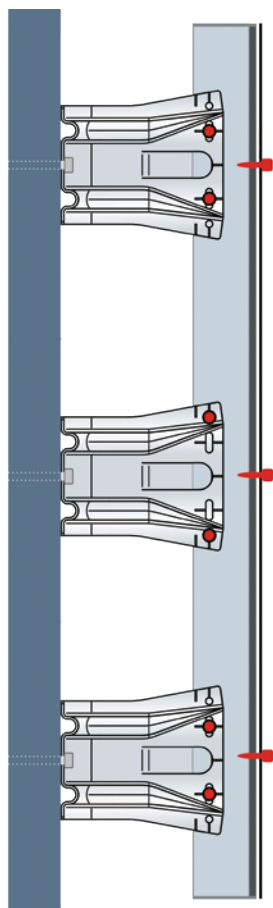

Subject to specifications, support profiles are installed storey by storey in lengths of 3 meters. The number and position of the fixed and sliding points of the vertical support profiles are determined according to the installation plan or the structural specifications. Special care must be taken to ensure that the joints of profiles and cladding panels are aligned. Cladding material must under no circumstances be mounted across a joint between profiles.

Fixed point

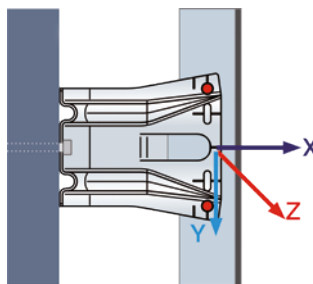

Sliding point

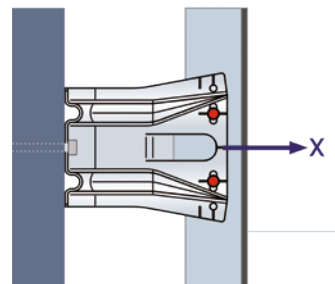

Combining different lengths of SPIDI® wall brackets is an easy way to compensate for even large wall-to-panel distances as well as protrusions or recesses in sections of the facade, as are often found in renovation projects. These kinds of applications truly benefit from the SPIDI® wall bracket's excellent lateral and torsional stability.

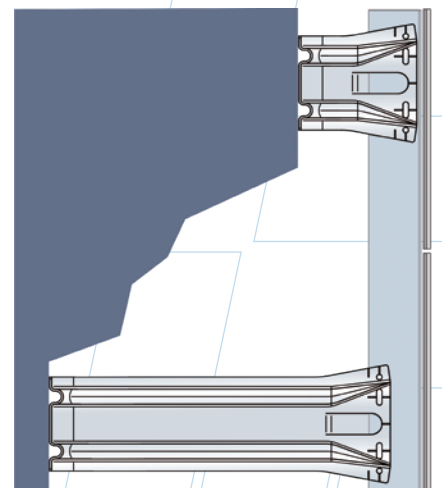

# INSTALLATION - SAFE AND EASY

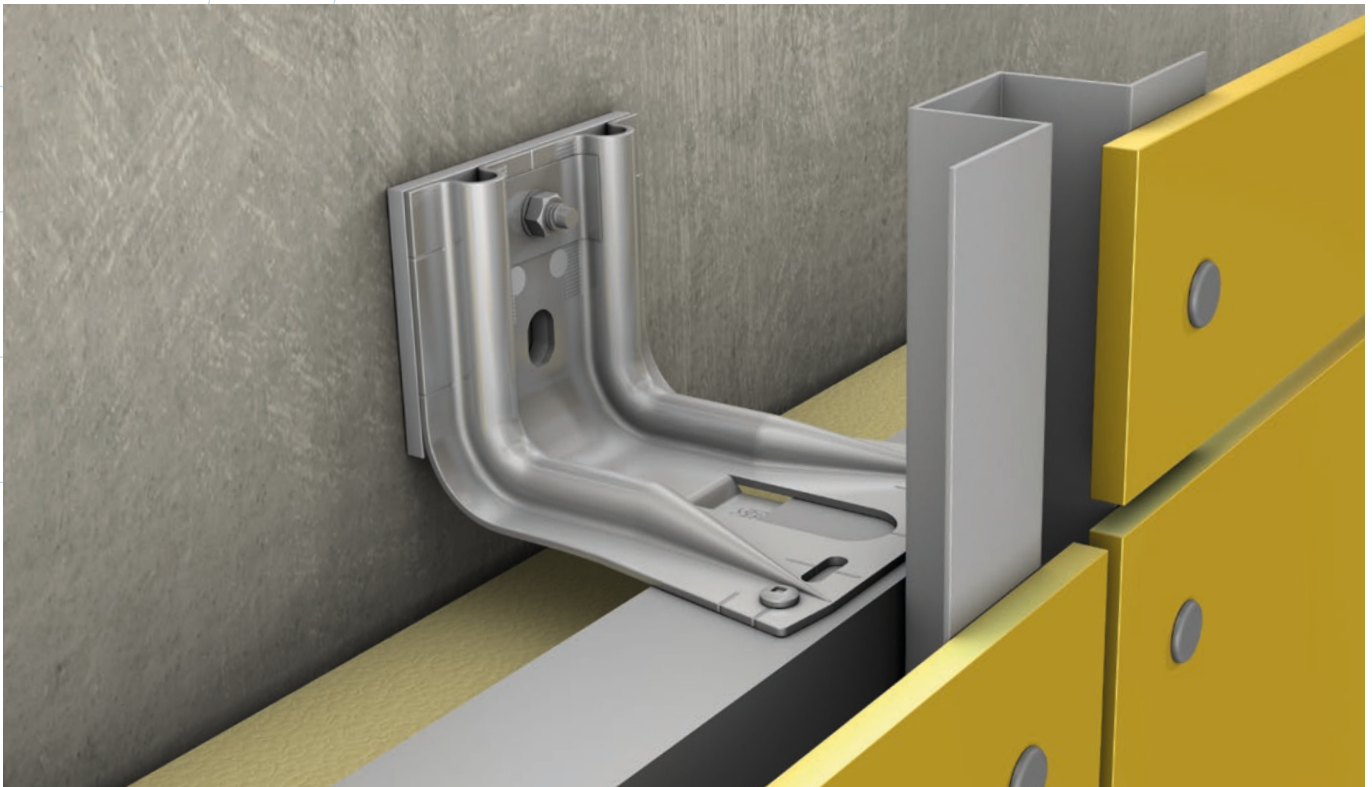

Over 45 years ago, the SPIDI® facade system was designed for secure, quick, and easy facade installation. Since then, the system has been expanded, adapted to growing insulation thicknesses, and steadily improved.

First, the facade is divided into sections based on the cladding material's requirements. Next, the SPIDI® substructure is installed with dowels or metal anchors as determined by the structural engineer, and the cladding is mounted. What makes SPIDI® wall bracket installation so quick and easy is each bracket's flexible use as either fixed or sliding point. This eliminates the need for storing two types of elements on work platforms and lifts, and simplifies all logistical and ordering processes. It also minimizes the potential for installation errors - making SPIDI® a safer system to use. Professional installation companies who have worked with other facade systems value the SPIDI® system in comparison.

## Spring Clips: Time Savers

One of the central installation advantages of SPIDI® wall brackets is the possibility to join profiles to brackets provisionally – without screwing or riveting – simply by slotting the profile into the spring clip. The spring clip supports swift work, allowing the profiles to be pre-installed without increased physical exertion. Adjustments to the substructure can then be made before the SPIDI® wall brackets and support profiles are joined with rivets or stainless steel screws. SPIDI® wall brackets designated as fixed points are normally placed in the center of the profile, to minimize support profile expansion from changes in temperature. The SPIDI® wall brackets serving as sliding points are placed on both sides of the fixed points. Where profiles of different lengths are used, the fixed points should be in line with each other where possible.

Thermal insulation boards are fixed in place mechanically to prevent them from peeling off. The ventilation cross-section dimensions must be designed in line with building physics specifications.

Once the SPIDI® substructure is complete, the facade cladding material is installed. Depending on the specifications, cladding elements can be mounted onto the substructure either visibly by riveting the cladding elements into place, by using hanging systems or adhesives for a concealed fixing system.

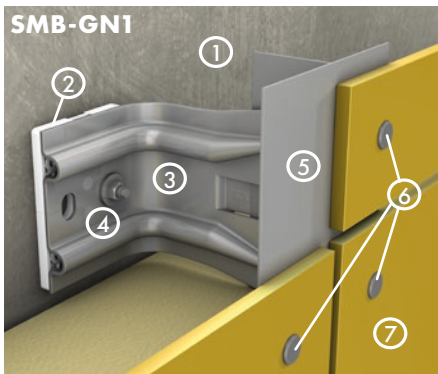

**RIVETED 1-layer substructure**

**FACADE CLADDING:**

Aluminium composite panels, fibre cement, glassfibre reinforced concrete, HPL panels, aluminium & steel sheets, render carrier boards

**SYSTEM DESCRIPTION:**

- 1 Wall
- 2 SPIDI® Thermostop
- 3 SPIDI® max wall bracket
- 4 SPIDI® washer plate with fixing element
- 5 T-profile/L-profile
- 6 Rivets
- 7 Facade cladding

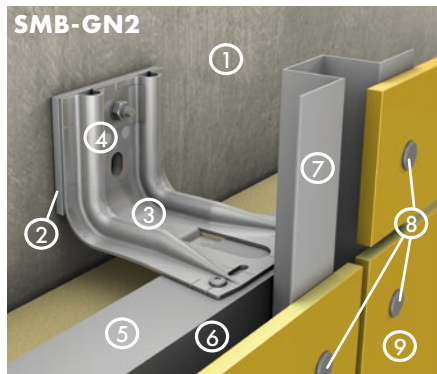

**RIVETED 2-layer substructure & wind barrier membrane**

**FACADE CLADDING:**

Aluminium composite panels, fibre cement, glassfibre reinforced concrete, HPL panels, aluminium & steel sheets, render carrier boards

**SYSTEM DESCRIPTION:**

- 1 Wall
- 2 SPIDI® Thermostop
- 3 SPIDI® max wall bracket
- 4 SPIDI® washer plate with fixing element
- 5 L-profile
- 6 Wind barrier membrane
- 7 HAT-profile
- 8 Rivets
- 9 Facade cladding

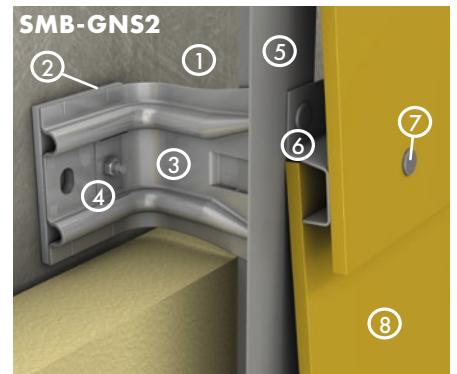

**RIVETED 2-layer substructure with clapboard cladding**

**FACADE CLADDING:**

Fibre cement, glassfibre reinforced concrete, HPL panels

**SYSTEM DESCRIPTION:**

- 1 Wall
- 2 SPIDI® Thermostop
- 3 SPIDI® max wall bracket
- 4 SPIDI® washer plate with fixing element
- 5 T-profile
- 6 Spacer profile
- 7 Rivets
- 8 Facade cladding

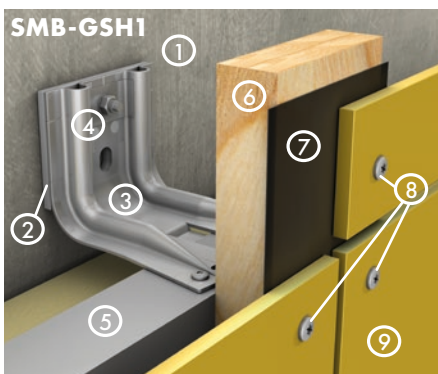

**TIMBER BATTEN 2-layer substructure**

**FACADE CLADDING:**

Fibre cement, glassfibre reinforced concrete, HPL panels, render carrier boards

**SYSTEM DESCRIPTION:**

- 1 Wall
- 2 SPIDI® Thermostop
- 3 SPIDI® max wall bracket
- 4 SPIDI® washer plate with fixing element
- 5 L-profile
- 6 Timber batten
- 7 EPDM sealing tape
- 8 Screws
- 9 Facade cladding

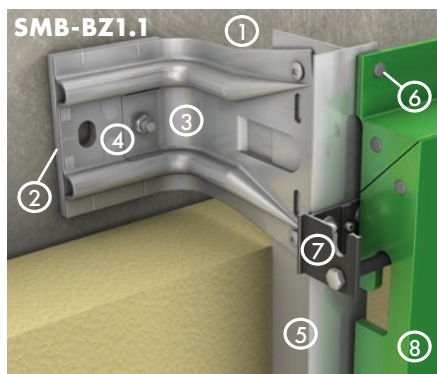

**BOLT HANGER 1-layer substructure**

**FACADE CLADDING:**

Aluminium composite material, aluminium & steel cassettes

**SYSTEM DESCRIPTION:**

- 1 Wall
- 2 SPIDI® Thermostop
- 3 SPIDI® max wall bracket
- 4 SPIDI® washer plate with fixing element
- 5 T-profile
- 6 Rivets
- 7 Bolt hanger
- 8 Facade cladding

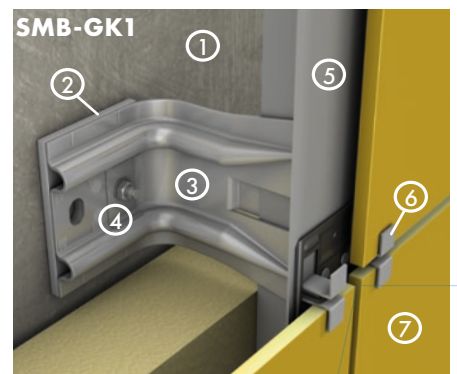

**CLAMP FIXING 1-layer substructure**

**FACADE CLADDING:**

Stoneware, ceramics

**SYSTEM DESCRIPTION:**

- 1 Wall
- 2 SPIDI® Thermostop
- 3 SPIDI® max wall bracket
- 4 SPIDI® washer plate with fixing element
- 5 T-profile
- 6 Stainless steel clamps
- 7 Facade cladding

## VISIBLE FIXING

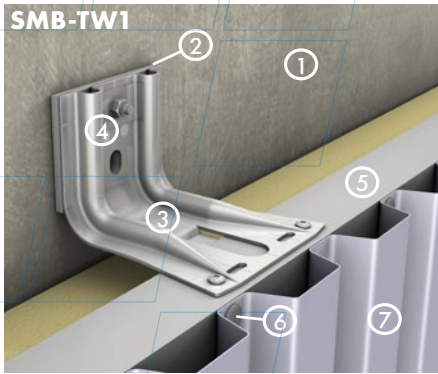

### RIVETED/SCREWED 1-layer substructure

FACADE CLADDING:  
Trapezoidal aluminium & steel sheeting

SYSTEM DESCRIPTION:

- 1 Wall
- 2 SPIDI® Thermostop
- 3 SPIDI® max wall bracket
- 4 SPIDI® washer plate with fixing element
- 5 L-profile
- 6 Rivets/screws
- 7 Facade cladding

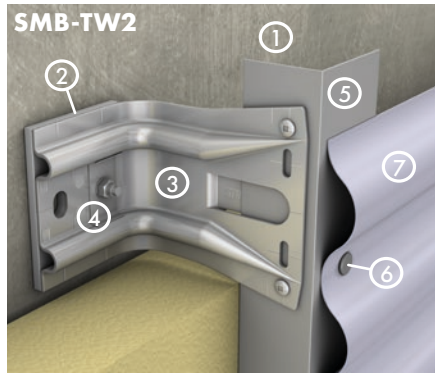

### RIVETED/SCREWED 1-layer substructure

FACADE CLADDING:  
Corrugated aluminium & steel sheeting

SYSTEM DESCRIPTION:

- 1 Wall
- 2 SPIDI® Thermostop
- 3 SPIDI® max wall bracket
- 4 SPIDI® washer plate with fixing element
- 5 L-profile
- 6 Rivets/screws
- 7 Facade cladding

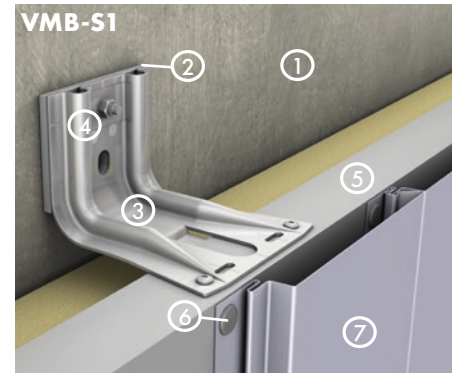

### RIVETED/SCREWED 1-layer substructure

FACADE CLADDING:  
Aluminium & steel siding

SYSTEM DESCRIPTION:

- 1 Wall
- 2 SPIDI® Thermostop
- 3 SPIDI® max wall bracket
- 4 SPIDI® washer plate with fixing element
- 5 L-profile
- 6 Rivets/screws
- 7 Facade cladding

## CONCEALED FIXING

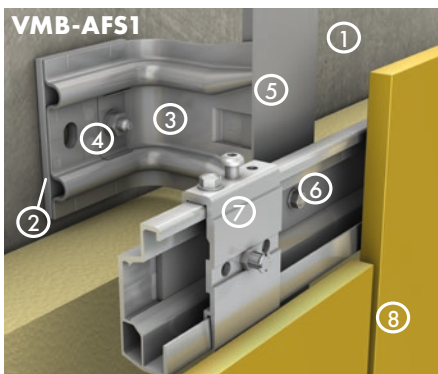

### HANGER SYSTEM 2-layer substructure

FACADE CLADDING:  
Fibre cement, stoneware, glassfibre reinforced concrete, HPL panels, ceramics, natural stone, coreboards, laminated glass

SYSTEM DESCRIPTION:

- 1 Wall
- 2 SPIDI® Thermostop
- 3 SPIDI® max wall bracket
- 4 SPIDI® washer plate with fixing element
- 5 T-profile/L-profile
- 6 Hanger-profile
- 7 Hanger adjustable/fixed
- 8 Facade cladding

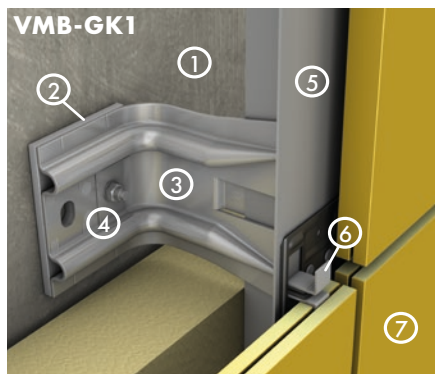

### CLAMP FIXING 1-layer substructure

FACADE CLADDING:  
Stoneware, natural stone

SYSTEM DESCRIPTION:

- 1 Wall
- 2 SPIDI® Thermostop
- 3 SPIDI® max wall bracket
- 4 SPIDI® washer plate with fixing element
- 5 T-profile
- 6 Stainless steel clamps
- 7 Facade cladding

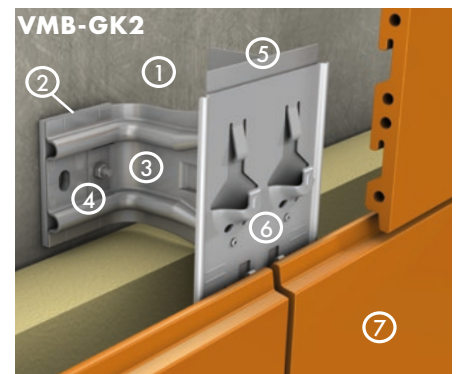

### SLIP RAIL 1-layer substructure

FACADE CLADDING:  
Terracotta, brick

SYSTEM DESCRIPTION:

- 1 Wall
- 2 SPIDI® Thermostop
- 3 SPIDI® max wall bracket
- 4 SPIDI® washer plate with fixing element
- 5 T-profile
- 6 Rail support
- 7 Facade cladding

## CONCEALED FIXING

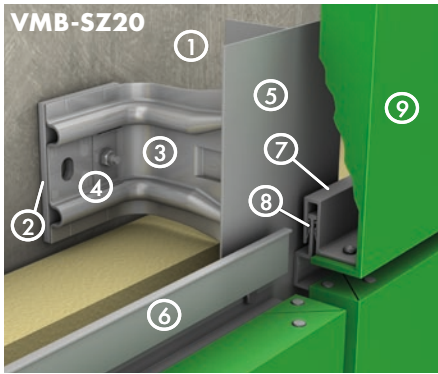

### SZ20 SYSTEM 1-layer substructure

FACADE CLADDING:  
Aluminium composite material

- SYSTEM DESCRIPTION:
- 1 Wall
  - 2 SPIDI® Thermostop
  - 3 SPIDI® max wall bracket
  - 4 SPIDI® washer plate with fixing element
  - 5 T-profile
  - 6 Z-profile
  - 7 S-profile
  - 8 Plastic clip
  - 9 Facade cladding

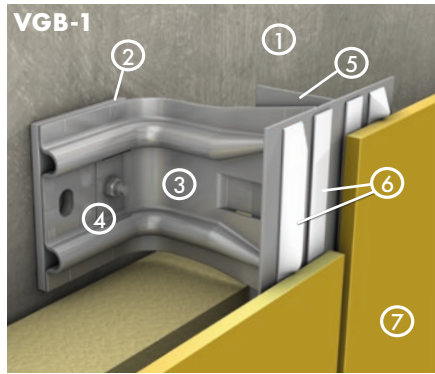

### VGB-1 ADHESIVE FIXING 1-layer substructure

FACADE CLADDING:  
Aluminium composite & HPL panels,  
fibre cement, glassfibre reinforced concrete,  
ceramics, natural stone

- SYSTEM DESCRIPTION:
- 1 Wall
  - 2 SPIDI® Thermostop
  - 3 SPIDI® max wall bracket
  - 4 SPIDI® washer plate with fixing element
  - 5 T-profile
  - 6 Adhesive system
  - 7 Facade cladding

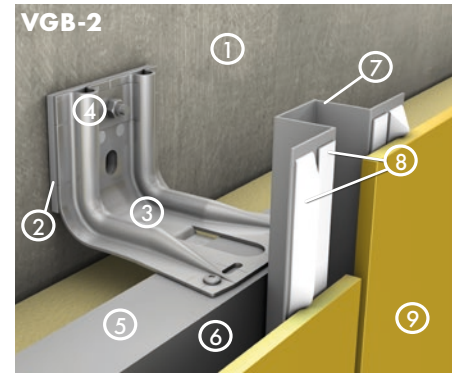

### VGB-2 ADHESIVE FIXING 2-layer substructure & wind barrier membrane

FACADE CLADDING: Aluminium composite & HPL panels, fibre cement, glassfibre reinforced concrete, ceramics, natural stone

- SYSTEM DESCRIPTION:
- 1 Wall
  - 2 SPIDI® Thermostop
  - 3 SPIDI® max wall bracket
  - 4 SPIDI® washer plate with fixing element
  - 5 L-profile
  - 6 Wind barrier membrane
  - 7 HAT-profile
  - 8 Adhesive system
  - 9 Facade cladding

## SUSPENDED CEILING

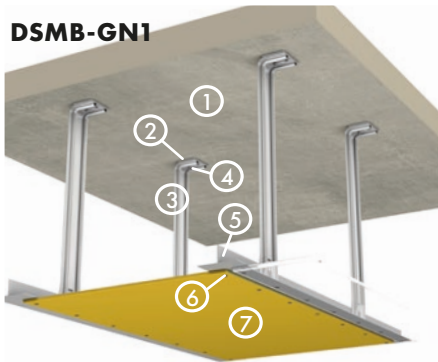

### DSMB-GN1 RIVETED 1-layer substructure

FACADE CLADDING:  
Aluminium composite panels, fibre cement,  
glassfibre reinforced concrete, HPL panels,  
aluminium & steel sheets, render carrier  
boards

- SYSTEM DESCRIPTION:
- 1 Ceiling
  - 2 SPIDI® Thermostop
  - 3 SPIDI® max wall bracket
  - 4 SPIDI® washer plate with fixing element
  - 5 T-profile
  - 6 Rivets
  - 7 Facade cladding

Further systems on request.

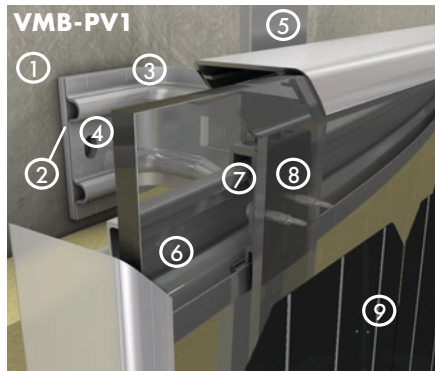

### VMB-PV1 HANGER SYSTEM 2-layer substructure

FACADE CLADDING:  
Photovoltaic modules with frame

- SYSTEM DESCRIPTION:
- 1 Wall
  - 2 SPIDI® Thermostop
  - 3 SPIDI® max wall bracket
  - 4 SPIDI® washer plate with fixing element
  - 5 T-profile/L-profile
  - 6 Hanger-profile
  - 7 Hanger adjustable/fixed
  - 8 Backrail
  - 9 Photovoltaic module

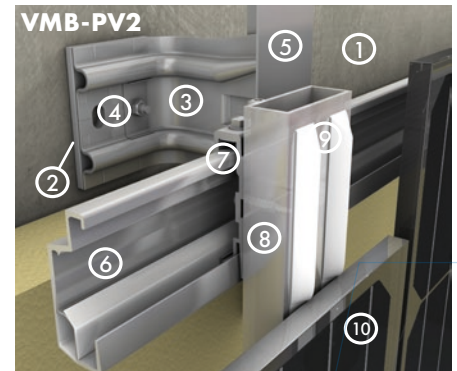

### VMB-PV2 HANGER SYSTEM 2-layer substructure

FACADE CLADDING:  
Photovoltaic modules glass-glass

- SYSTEM DESCRIPTION:
- 1 Wall
  - 2 SPIDI® Thermostop
  - 3 SPIDI® max wall bracket
  - 4 SPIDI® washer plate with fixing element
  - 5 T-profile/L-profile
  - 6 Hanger-profile
  - 7 Hanger adjustable/fixed
  - 8 Backrail
  - 9 Adhesive system
  - 10 Photovoltaic module



## FEATURE PROJECTS

The patented SPIDI® facade system offers perfect solutions for sophisticated architecture and facade design as seen in the following reference projects:

- A facade with a lot of curve areas stretching high and wide on an office building in Vienna (large photo).
- The curved glass facade of a hospital in Baden, Austria, implementing a three-layer SPIDI® substructure
- SPIDI® was used in a residential complex where wall-to-panel distances ranged from 200 to 800 mm. This three dimensional design features offset HPL panels mounted vertically and horizontally onto a 1-layer SPIDI® substructure.
- The HPL facade on the Technology and Research Center in Wieselburg, Austria, using adhesive fixing on a SPIDI® substructure.

The SPIDI® technical team at Slavonia supports each project throughout all stages from planning to execution.

**Office building**  
Vienna, Austria  
Aluminium composite panels,  
3400 m<sup>2</sup>



**Aupark Bratislava/Slovakia**  
Natural stone, 3000 m<sup>2</sup>

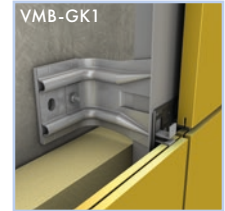

**Hypo Alpe Adria Zagreb/Croatia**  
Eternit Fiber cement, 14000 m<sup>2</sup>



**Technology Center Wieselburg/Austria**  
HPL, 1600 m<sup>2</sup>



**Hospital in Baden/Austria**  
Laminated glass, 9800 m<sup>2</sup>



**Residential complex/Vienna, Austria**  
HPL, 750 m<sup>2</sup>





## BUILDING FOR THE FUTURE

This was the project intention for renovating the outdated ribbed concrete facade of a shopping center in Vösendorf near Vienna, Austria. The new facade features steel sidings on a SPIDI® steel substructure (with double corrosion protection) using SPIDI® wall brackets of 540 mm length. The reconstruction of Vienna's Sofiensäle ballroom venue, which was destroyed by a fire in 2001, required careful handling of the difficult, heavily damaged substrate. After a thorough substrate assessment - the critical factor for a correct installation - the SPIDI® team chose a 1-layer SPIDI® aluminium substructure with visible fixings. Universally suited for facades and suspended ceilings alike, the SPIDI® system was applied to a number of large scale projects, delivering perfect facades to the Sonnwendviertel residential complex as well as the Vienna University Campus, the Rudolfsheim care home and the Vienna Hauptbahnhof train station.

**Shopping Center**  
 Vösendorf, Austria  
 Steel siding, 8300 m<sup>2</sup>

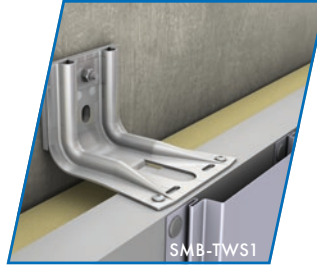

SMB-TWS1

**Residential complex**  
**Sonnwendviertel**/Vienna, Austria  
 Eternit fiber cement, 10200 m<sup>2</sup>

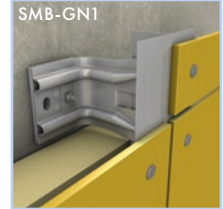

SMB-GN1

**Office-, Residential- & Event-Facility "Sofien-Säle"**/Vienna, Austria  
 Stoneware, 1650 m<sup>2</sup>

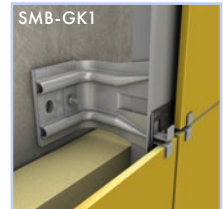

SMB-GK1

**B & F Logistics Center**/Vienna, Austria  
 HPL, 2450 m<sup>2</sup>

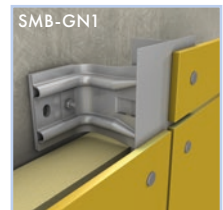

SMB-GN1

**Care home Rudolfshheim**/Vienna, Austria  
 Steel panelling, 6900 m<sup>2</sup>

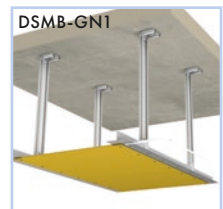
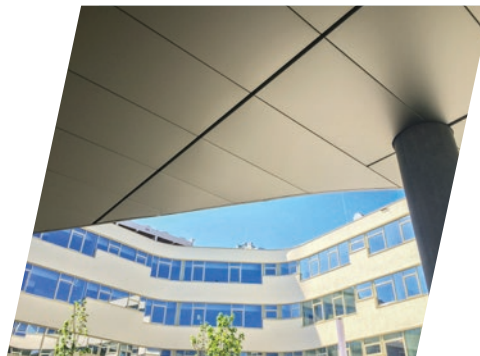

DSMB-GN1

**WU university campus**/Vienna, Austria  
 Corten steel, 3200 m<sup>2</sup>



SMB-GN2



Your **SPIDI®** consultant and sales partner